

## Wheel alignment specifications, Golf

These specifications apply to all engines.

- ◆ Explanation of PR Nos. can be found here → .

The ride heights shown in the table refer to dimension -a-.

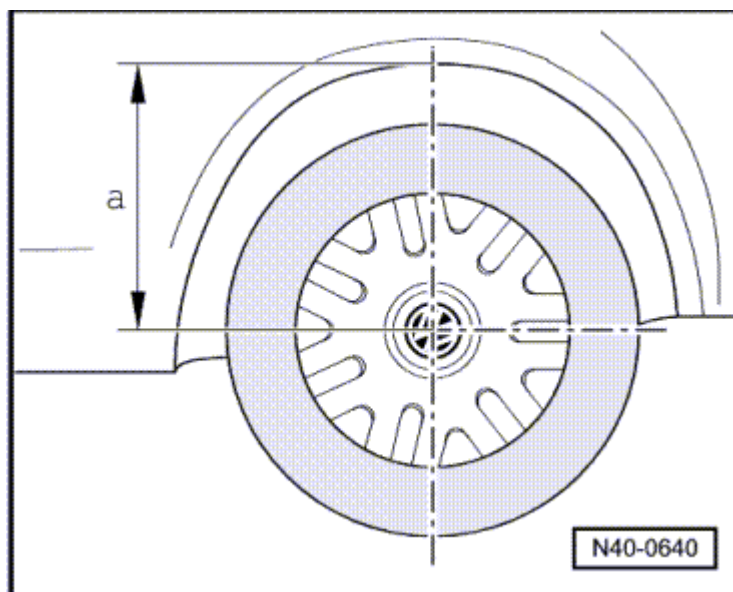

Front axle	Standard running gear	Sports running gear except 18' wheels	Sports running gear with 18' wheels	Heavy-duty running gear
<b>PR numbers</b>	<b>2UA</b>	<b>2UC</b>	<b>G02, G07, 2UC</b>	<b>2UB</b>
Total toe (without load)	10' ± 10'	10' ± 10'	10' ± 10'	10' ± 10'
→ Camber (in straight-ahead position)	-30' ± 30'	-41' ± 30'	-41' ± 30'	-14' ± 30'
Maximum permissible difference between sides	max. 30'	max. 30'	max. 30'	max. 30'
→ Toe-out on turns <sup>1)</sup> at 20° left and right lock	1°38' ± 20'	1°40' ± 20'	1°40' ± 20'	1°38' ± 20'
Caster	7°34' ± 30'	7°47' ± 30'	7°47' ± 30'	7°17' ± 30'
Maximum permissible difference between sides	max. 30'	max. 30'	max. 30'	max. 30'
Ride height	382 ± 10 mm	367 ± 10 mm	367 ± 10 mm	402 ± 10 mm

<sup>1)</sup> Toe-out on turns can be displayed as a negative value on the wheel alignment computer, depending on the manufacturer.

Front axle	Sports running gear GTI	Sports running gear GTI US version	Sports running gear R32
<b>PR numbers</b>	<b>G08</b>	<b>G11</b>	<b>G09</b>
Total toe (without load)	10' ± 10'	10' ± 10'	10' ± 10'
→ Camber (in straight-ahead position)	-44' ± 30'	-30' ± 30'	-43' ± 30'
Maximum permissible difference between sides	max. 30'	max. 30'	max. 30'

→ Toe-out on turns <sup>1)</sup> at 20° left and right lock	1°22' ± 20'	1°38' ± 20'	1°20' ± 20'
Caster	7°47' ± 30'	7°34' ± 30'	7°47' ± 30'
Maximum permissible difference between sides	max. 30'	max. 30'	max. 30'
Ride height	360 ± 10 mm	382 ± 10 mm	362 ± 10 mm

1) Toe-out on turns can be displayed as a negative value on the wheel alignment computer, depending on the manufacturer.

These specifications apply to all engines.

◆ Explanation of PR Nos. can be found here → .

Rear axle, front-wheel drive and 4WD	Standard running gear	Sports running gear except 18' wheels	Sports running gear with 18' wheels	Heavy-duty running gear
→ Camber	-1°20' ± 30'	-1°20' ± 30'	-1°45' ± 30'	-1°20' ± 30'
Maximum permissible difference between sides	max. 30'	max. 30'	max. 30'	max. 30'
Total → toe (at specified → camber)	+10' ± 12,5'	+10' ± 12,5'	+10' ± 12,5'	+10' ± 12,5'
Max. permissible deviation from direction of travel	max. 20'	max. 20'	max. 20'	max. 20'
Ride height	380 ± 10 mm	365 ± 10 mm	365 ± 10 mm	400 ± 10 mm

Rear axle, front-wheel drive and 4WD	Sports running gear GTI	Sports running gear GTI US version	Sports running gear R32
→ Camber	-1°45' ± 30'	-1°20' ± 30'	-1°45' ± 30'
Maximum permissible difference between sides	max. 30'	max. 30'	max. 30'
Total → toe (at specified → camber)	+10' ± 12,5'	+10' ± 12,5'	+10' ± 12,5'
Max. permissible deviation from direction of travel	max. 20'	max. 20'	max. 20'
Ride height	365 ± 10 mm	380 ± 10 mm	360 ± 10 mm